

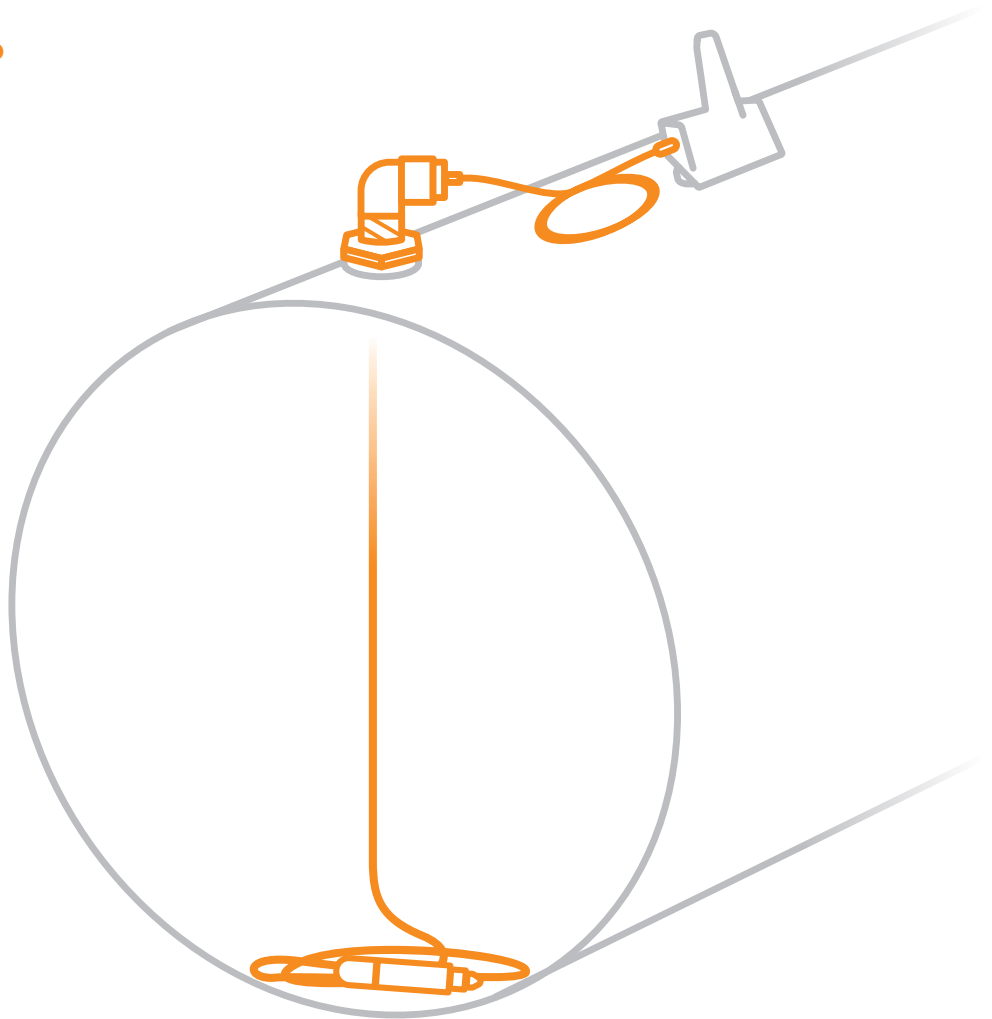

## Addendum—Installation Guide

# Tank Level Monitor Hydrostatic Pressure Gauge Reference

TM5240HP



### Original instructions

Read this manual before using the equipment

Retain this manual for future use

Published on: Friday, June 12, 2026

Document ID: GRA-0136-EN\_001 IM\_TM5240HP\_ADD\_GREF 2026-06-11

## Copyright

Copyright © 2026 Otodata All Rights Reserved.

Contains information owned by Otodata and/or its affiliates. Do not copy without prior written permission from Otodata.

Other product and company names may be trademarks or registered trademarks of other companies, and are the property of their owners. They are used only for explanation, without intent to infringe.

## Intended purpose

The purpose of this guide is to provide instructions and information for the safe installation of the Otodata Tank Level Monitor (Hydrostatic Pressure) TM5240HP utilizing the Gauge Reference sensor configuration

## Contact information

Otodata  
Head Office  
1212 Louvain O.,  
Montreal, Qc H4N 1G5, Canada  
otodata.com

## Support

### North America

support@otodata.com  
go.otodata.com/support  
+1 (514) 673-0244 | +1 (844) 763-3344 (toll-free)

### Europe

support@otodata.eu  
+48 32 630 41 84

### After hours emergency support

6pm to 8am EST  
+1 (833) 529-9499\*

\*Only North America. Only call this number in an emergency.

# Contents

1	Safety information .....	5
1.1	Safety notices .....	5
1.2	Special safety instructions.....	6
1.3	Intended Use .....	7
1.4	Identification labels .....	8
1.5	PPE requirements.....	9
1.6	Operating environment.....	10
1.7	Residual risks.....	10
1.8	Battery .....	10
1.9	Liability disclaimer .....	11
2	Hardware description .....	12
2.1	Overview.....	12
2.2	Overview of the communicator.....	13
2.3	Overview of the Gauge Reference sensor.....	14
2.4	Dimensions.....	15
2.5	Device identification .....	15
3	Before installation .....	16
3.1	Checking tank compatibility .....	16
3.2	Choosing the right port hole .....	17
3.3	Maximizing communicator performance .....	18
4	Installation.....	21
4.1	Box contents .....	22
4.2	Tools and equipment .....	23
4.3	Installing the Gauge Reference sensor .....	23
4.4	Mounting the communicator .....	26
5	Maintenance .....	30
5.1	Cleaning the sensor .....	30
6	Troubleshooting .....	32
7	Specifications.....	33
7.1	Device specifications .....	33

7.2	Environmental specifications.....	35
7.3	Certification specifications.....	35
8	Regulatory.....	36
8.1	Federal Communications Commission (FCC).....	37

# 1 Safety information

This section provides an overview of all safety aspects for the protection of people as well as safe and uninterrupted operation. Other task related safety instructions are included in the specific sections.

## 1.1 Safety notices

The following safety notice formats are used in this guide. Safety notices are used at the start of sections or embedded in operating instructions.

Make sure you fully understand and comply with the notices in this guide.



### **DANGER**

#### **Risk of death!**

Indicates a hazardous situation which, if not avoided, could result in death.

### **WARNING**

#### **Risk of serious injury or death!**

Indicates a hazardous situation which, if not avoided, could result in death or serious injury.

### **Caution**

#### **Risk of serious injury or damage!**

Indicates a hazardous situation which, if not avoided, could result in serious injury or damage to your equipment.



### **Notice**

Indicates an important situation which, if not avoided, may seriously impair operations.



### **Information**





Additional information relating to the current section.

## 1.2 Special safety instructions

To indicate specific hazards, this guide uses the following symbols.

**Table 1 • Hazard symbols**

Make sure you fully understand and comply with the notices in this guide.

Symbol	Meaning
	General warning
	Hazardous substance
	Electrostatic charging hazard
	Explosion hazard
	Crush or trapping hazard

### 1.3 Intended Use

The Tank Level Monitor (Hydrostatic Pressure) TM5240HP (the monitor) is intended exclusively for use in accordance with the information and safety instructions provided in this guide. The monitor is to be used for measuring and recording the level of a substance in a tank.

Intended use includes compliance with all the information and safety instructions in this manual. Any use that deviates from, or goes beyond the intended use or ignores the safety instructions in this guide or the identification labels on the device, is considered misuse.

#### **WARNING**

##### **Danger due to misuse!**

Only operate the device if it is in an undamaged and orderly condition.

Observe all warning information on the identification labels on the device.

Never deviate from the prescribed maintenance intervals and procedures.

Never modify or attempt to modify the device.

Never allow untrained personnel to operate or service the device. Substitution of components may compromise the intrinsic safety of the device.

## 1.4 Identification labels

Identification labels on the communicator may contain warnings for potential hazards. These identification labels must not be defaced or removed.

Figure 1 • Identification label locations

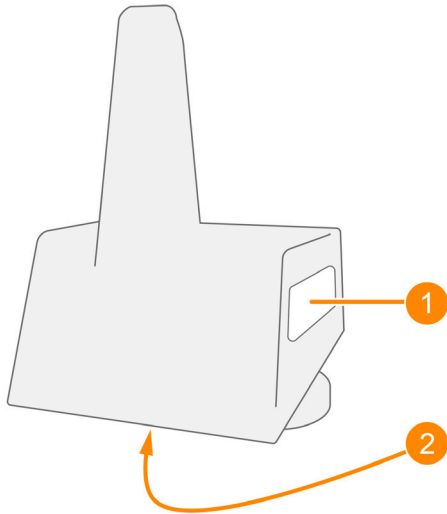

- 1 Identification label on the side of the communicator
- 2 Main identification label on the base of the communicator

The following are examples of identification labels:

Figure 2 • Identification label on communicator side

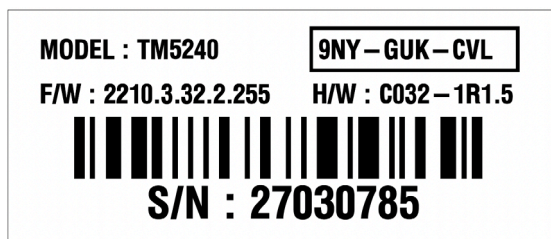
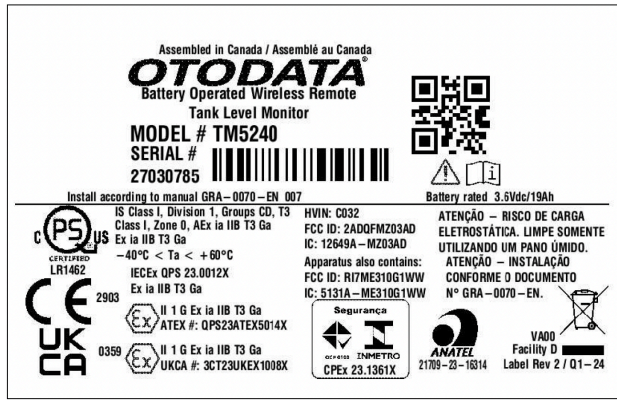

Figure 3 • Identification label on communicator base



## 1.5 PPE requirements



### WARNING

#### Risk of serious injury or death!

When installing the monitor, you may come into contact with hazardous and flammable substances:

- Use personal protective equipment (PPE) such as protective gloves and safety glasses as required.
- Wear appropriate protective clothing and footwear.
- Do not eat, drink, or smoke when installing the monitor.
- Follow local guidelines and safety requirements.

## 1.6 Operating environment

Otodata recommends the monitor to be installed outside. This maximizes signal strength and therefore the performance of the communicator.



### WARNING

#### Risk of serious injury or damage!

Potential electrostatic charging hazard. To clean the communicator, wipe only with a damp cloth. Do not pressure wash.

## 1.7 Residual risks

The section provides an overview of the residual risks to be aware of when installing the monitor.

### 1.7.1 Pinch points



### WARNING

#### Risk of crushed or trapped hands!

You can mount the communicator directly on the tank using its builtin magnetic feet, or with a magnetic mounting bracket. Make sure you are aware of the pinch points between the communicator or bracket and the tank.

### 1.7.2 Battery

The battery inside the communicator cannot be changed because the communicator is a sealed unit.

Contact your local recycling facility that accepts electrical or electronic equipment or batteries to learn how to correctly dispose of the communicator.

## 1.8 Battery

Installation and maintenance work must only be carried out by trained personnel. Other personnel are not authorized to carry out this work.

## 1.8.1 Installation personnel

For training, Otodata provides installation technicians with the following:

- Installation documentation and videos.
- Quality checks on all installations via photo submission of installations.
- Ongoing feedback for continuous improvement.

**Installation technicians must do the following:**

- Make sure they are familiar with the type of work required for installing Otodata products on tanks.
- Follow Otodata protocols for optimizing the performance of the monitor.

## 1.8.2 Maintenance personnel

Maintenance technicians must be trained before they can maintain the monitor.

Maintenance technicians must be familiar with the type of work required for the operation and maintenance of the monitor.

## 1.9 Liability disclaimer

The Otodata Customer (the Owner) assumes full responsibility and liability for any damage, loss, or injury caused to users (homeowners, personnel, and or any third party) of the Product (the monitor) arising from improper installation, usage, or maintenance of the Product.

Otodata disclaims all liability for any costs, damages, or consequences resulting from the Customer's failure to comply with these responsibilities. By using the Product, the Customer acknowledges and accepts these responsibilities.

Refer to the terms and conditions for a complete list of Owner (Customer) responsibilities.

### 1.9.1 Owner responsibilities

The owner of an Otodata tank level monitor is responsible for the following:

- Establishing a maintenance schedule to ensure the monitor operates correctly.
- Making sure the monitor is not altered in a way that may void the warranty.
- Asking the personnel responsible for filling the tank to inspect the installation integrity of the monitor.

► For more information, see Maintenance on [page 30](#).

## 2 Hardware description

To install the Tank Level Monitor (Hydrostatic Pressure) TM5240HP (the monitor), you must be familiar with the descriptions of the main parts.

### 2.1 Overview

The monitor is used for measuring and transmitting the level of a substance in a tank.

The monitor can be used to measure more than 100 substances. For the full list of substances, contact Otodata Customer Support and ask for the Tank Level Monitor (Hydrostatic Pressure) TM5240HP Sensor Compatibility Chart.

The monitor is made up of a remote sensor and a communicator. The sensor measures the level of the substance in a tank, and the communicator transmits the data to Otodata's Nee-Vo Portal.

This guide covers the following sensor model:

- Gauge Reference sensor

## 2.2 Overview of the communicator

The communicator is used to send tank level data and other information about the monitor to the Nee-Vo Portal.

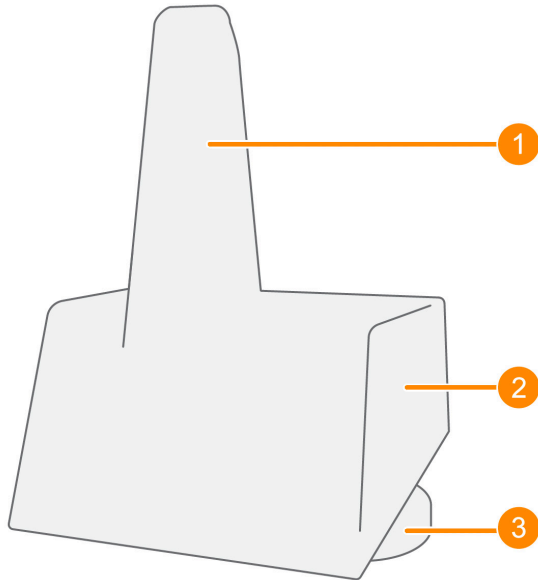

- 1 Antenna
- 2 Communicator body
- 3 Mounting magnets

**Table 2 • Data sent by the communicator**

Data sent	Description
Tank level	The level of the in-tank substance calculated based on the pressure exerted by the substance in-tank The Nee-Vo Portal displays this value in bar
Temperature	The temperature of the in-tank substance in Celsius or Fahrenheit
Communicator battery	The battery charge measured in volts

## 2.3 Overview of the Gauge Reference sensor

The Gauge Reference sensor is installed inside a tank through a port hole. The sensor cable is fixed and sealed and cannot be adjusted. It terminates at a female M12 connector at the elbow exit, which connects to the communicator via the included M12 male-to-male extension cable (30 inch / 0.77 m).

Figure 3 • Gauge reference sensor

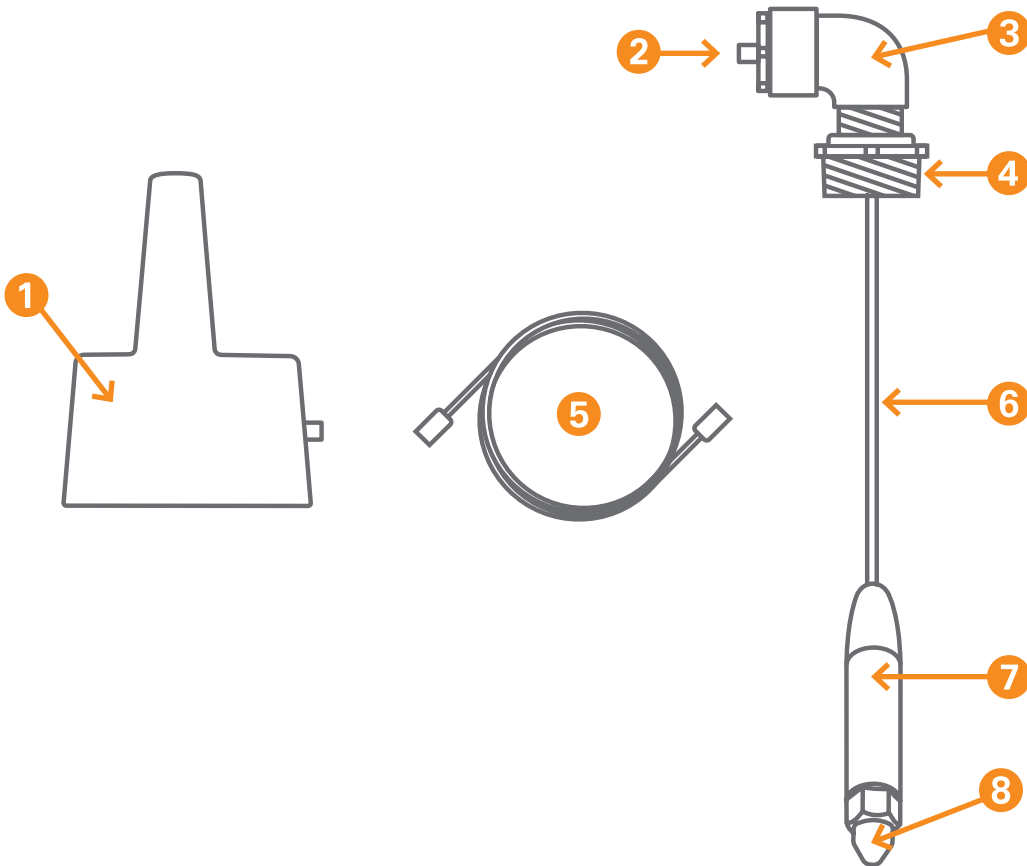

- |   |  |
|---|--|
| 1 | Communicator with female M12 bulkhead              |
| 2 | Nylon Plug 1" NPT with female M12 bulkhead         |
| 3 | Polypropylene elbow 1" NPT                         |
| 4 | Polypropylene reducer 2" NPT                       |
| 5 | M12 male-to-male extension cable, 30 inch (0.77 m) |
| 6 | Hytrel jacketed cable                              |
| 7 | Druck sensor/transducer SS316L                     |
| 8 | Kynar (PVDF) depth cone                            |

## 2.4 Dimensions

Figure 4 • Dimensions of the communicator

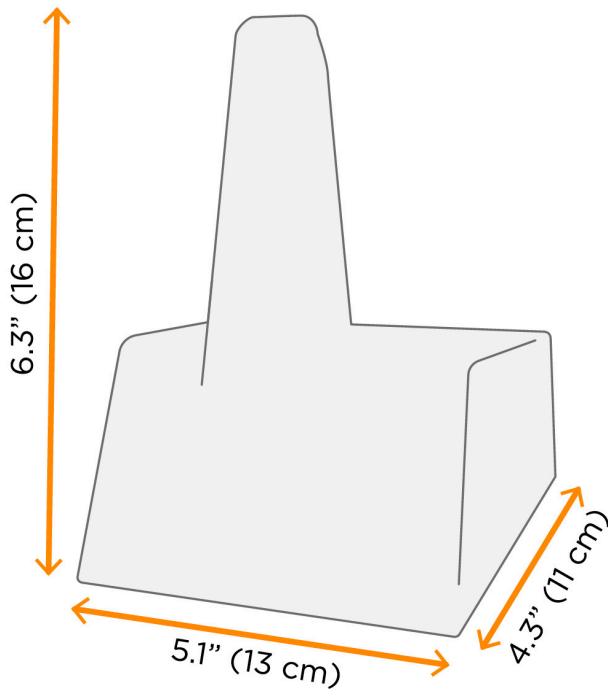

## 2.5 Device identification

The identification labels are located on the side and on the base of the communicator.

► For more information, see *Identification labels* on [page 8](#)

The identification labels include the following information about the communicator:

- Model number
- Serial number
- Compliance markings

## 3 Before installation

This section explains what you need to do before installing the monitor.

### 3.1 Checking tank compatibility

To make sure sensor readings are accurate, you must check that the tank in which you are installing the HP monitor is compatible with the Gauge Reference sensor. Use the compatibility table below to select the correct SKU based on your tank height.

To check tank compatibility, do the following:

1. Measure the height of the tank ①.
2. Use the following table to confirm the tank height is compatible with the Gauge Reference sensor SKU you are installing.

Figure 5 • Measuring tank height

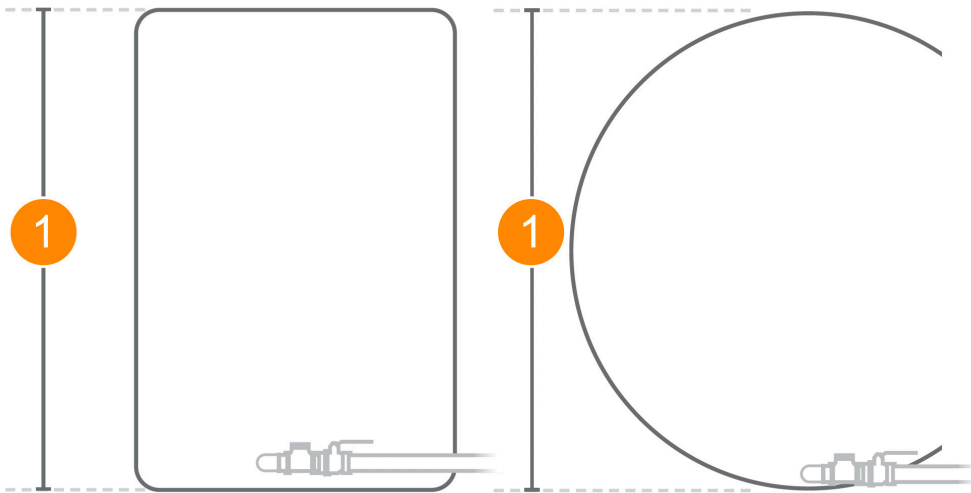

### 3.1.1 Gauge Reference model

**Table 3 • Compatible tank heights for gauge reference models**

Tank height	Cable length	Communicator and sensor SKU	Sensor SKU
0 ft – 4 ft (0 m – 1.2 m)	6 ft (1.8 m)	TM5240HP-VA00-CNEE-PSHDRGB013	ACPSHDRGB013
3 ft – 6.5 ft (1 m – 2 m)	9 ft (2.7 m)	TM5240HP-VA00-CNEE-PSHDRGB020	ACPSHDRGB020
6.5 ft – 13 ft (2 m – 3.96 m)	15 ft (4.6 m)	TM5240HP-VA00-CNEE-PSHDRGB040	ACPSHDRGB040
13 ft – 26 ft (3.96 m – 8 m)	30 ft (9.1 m)	TM5240HP-VA00-CNEE-PSHDRGB080	ACPSHDRGB080
26 ft to 32 ft (8 m to 10 m)	36 ft (11 m)	TM5240HP-VA00-CNEE-PSHDRGB100	ACPSHDRGB100
32 ft to 52 ft (10 m to 16 m)	55 ft (16.8 m)	TM5240HP-VA00-CNEE-PSHDRGB160	ACPSHDRGB160



#### Information

SKUs can vary depending on region, sensor cable type, and branding. For example, the following values may differ:

- VA00: The regional code.
- CNEE: For transmitters branded with a customer's logo.

### 3.2 Choosing the right port hole

The information in this section applies to the Gauge Reference sensor.

The HP monitor is designed to be permanently installed. To choose a suitable port hole for installation, the following must be true:

- The port hole is free of rust and dirt.
- The port hole allows you to position the communicator away from a wall.
- The port hole allows you to position the communicator away from the t-vent of the tank.

**Notice**

Do not install the Gauge Reference sensor in the port hole used for filling the tank.

In the following image, port holes **1**, **2**, and **3** are all suitable locations for installing the monitor.

**Figure 6 • Selecting a port hole**

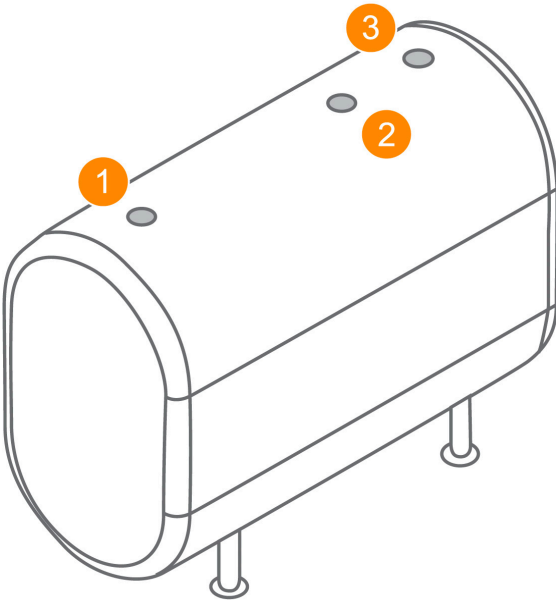

### 3.3 Maximizing communicator performance

To maximize communicator performance, you must install the communicator in a suitable position.

Communicator performance is maximized when the following is true:

- The communicator is positioned away from any walls.
- The communicator is in a vertical position with the antenna pointing skywards.

The following image shows examples of optimal and suboptimal communicator positions on a typical tank.

**Figure 7 • Communicator positions**

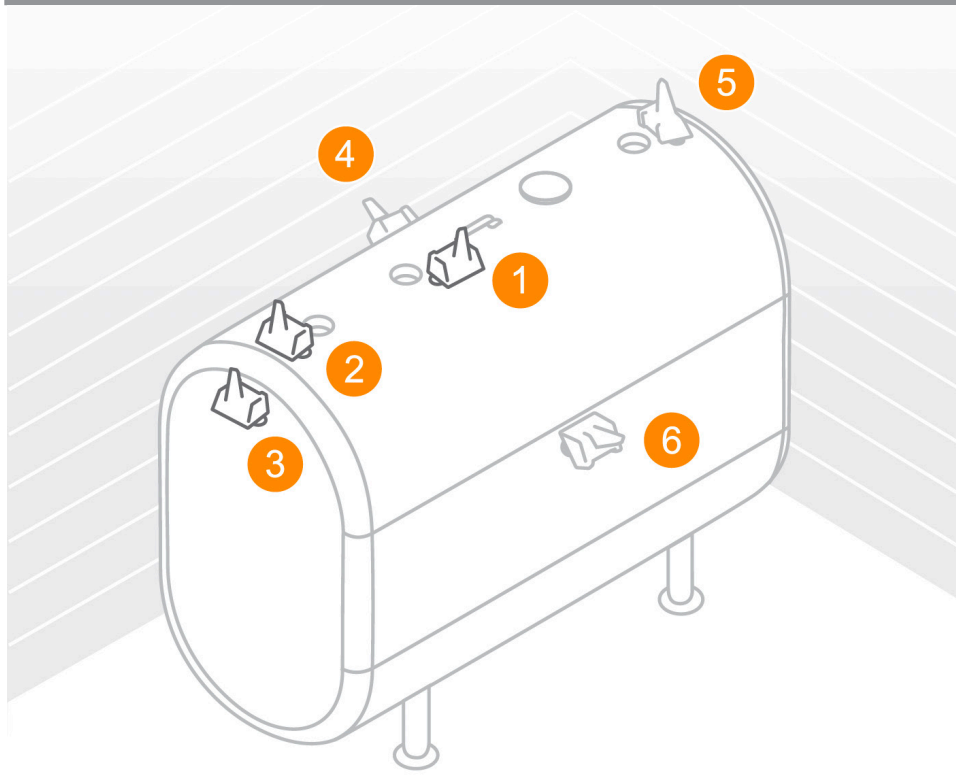

Communicator position	Effect on performance
<p><b>1</b> Optimal:</p> <ul style="list-style-type: none"> <li>• Away from walls</li> <li>• Vertical orientation with antenna pointing skywards</li> </ul>	<ul style="list-style-type: none"> <li>• Maximizes signal strength which reduces battery drain</li> <li>• Reduces chance of signal interference</li> </ul>
<p><b>2</b> Optimal:</p> <ul style="list-style-type: none"> <li>• Away from walls</li> <li>• Vertical orientation with antenna pointing skywards</li> </ul>	<ul style="list-style-type: none"> <li>• Maximizes signal strength which reduces battery drain</li> <li>• Reduces chance of signal interference</li> </ul>
<p><b>3</b> Optimal:</p> <ul style="list-style-type: none"> <li>• Away from walls</li> <li>• Vertical orientation with antenna pointing skywards</li> </ul>	<ul style="list-style-type: none"> <li>• Maximizes signal strength which reduces battery drain</li> <li>• Reduces chance of signal interference</li> </ul>
<p><b>4</b> Suboptimal:</p> <ul style="list-style-type: none"> <li>• Too close to wall</li> <li>• Horizontal orientation and antenna pointing away from sky</li> </ul>	<ul style="list-style-type: none"> <li>• Reduces signal strength which increase battery drain</li> <li>• Increases chance of signal interference</li> </ul>

Communicator position	Effect on performance
<p>5 Suboptimal:</p> <ul style="list-style-type: none"> <li>• Too close to wall</li> </ul>	<ul style="list-style-type: none"> <li>• Reduces signal strength which increases battery drain</li> <li>• Increases chance of signal interference</li> </ul>
<p>6 Suboptimal:</p> <ul style="list-style-type: none"> <li>• Horizontal orientation and antenna pointing away from sky</li> </ul>	<ul style="list-style-type: none"> <li>• Reduces signal strength which increases battery drain</li> <li>• Increases chance of signal interference</li> </ul>

## 4 Installation

This section describes the installation procedure for the monitor.



### WARNING

Take care when installing the monitor in tanks that contain flammable substances.

### Caution

Always carefully read all warning tags attached to the sensor cable before installing the monitor.

Figure 8 • Selecting a port hole



**READ BEFORE UNCOILING CABLE**  
**AGGRESSIVE UNCOILING CAN DAMAGE**  
**THE CABLE SLEEVE.**

**IMPORTANT: When straightening the cable,**  
**DO NOT OVERBEND.**



If damage found, please contact Otodata support.  
**North America +1 (844) 763-3344**  
**Europe +48 32 630 40 36**

### Caution

Always follow your local regulations and standards. Consult with certified personnel to make sure your installation is compliant.

## 4.1 Box contents

This section provides an overview of the components included in the box for the gauge reference model.

### 4.1.1 Gauge Reference model

Figure 9 • Box contents for gauge reference model

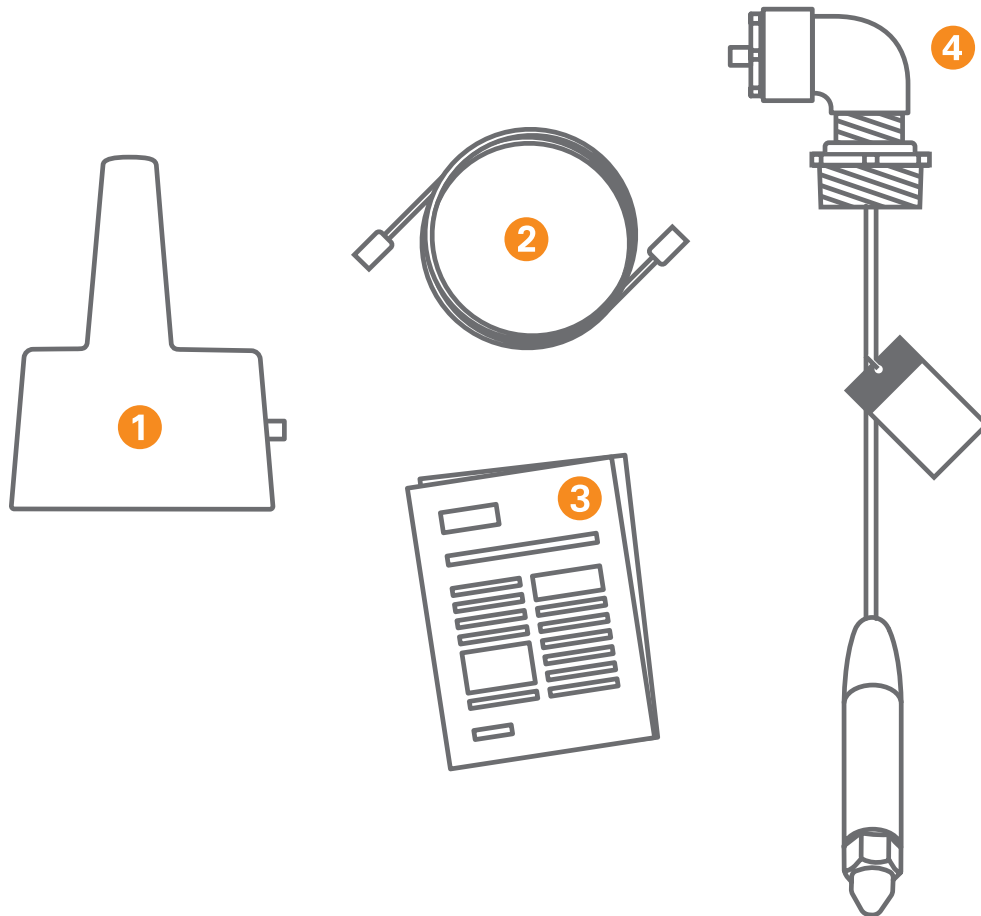

- 
- 1 Communicator
  - 2 M12 male-to-male extension cable, 30 inch (0.77 m)
  - 3 Safety and Specifications sheet
  - 4 Sensor, cable with warning tag, elbow, and connector
-

## 4.2 Tools and equipment

Before you install the monitor, make sure you have the following tools and equipment:

- Approved sealant (tape or paste)
- 14" pipe wrench
- Tape measure
- A way of recording all of the information relating to the installation. For example, this may include the following:
  - The serial number of the communicator
  - The dip level of the tank
  - The dimensions of the tank
  - The name of the substance in the tank
- If you are installing the monitor on a plastic tank, at least two tie wraps for mounting the communicator

## 4.3 Installing the Gauge Reference sensor

This section describes the installation procedure for the Gauge Reference sensor.

The Gauge Reference sensor is installed inside the tank using a port hole.



### Information

To prevent contamination of the in-tank substance, make sure the port hole is free of rust and dirt.

**To install the Gauge Reference sensor, follow these steps:**

### Caution

Always carefully read all warning tags attached to the sensor cable before installing the monitor.

1. Read and then remove the warning tag attached to the sensor cable.

2. Apply an approved sealant to threads **1** (nylon plug 1" NTP with M12 bulkhead) and **2** (polypropylene reducer 2" NPT).



**Notice**

Only use a sealant approved for use with the in-tank substance.

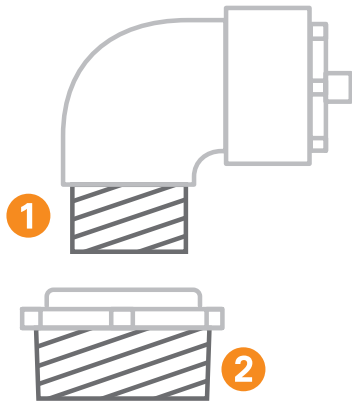

3. Using a wrench, slowly tighten threads **1** and **2**.

**Caution**

Do not overtighten the threads or you may damage the pipe fittings.

4. Insert the sensor into the tank by gently lowering it through the port hole until you feel it touch the bottom of the tank.

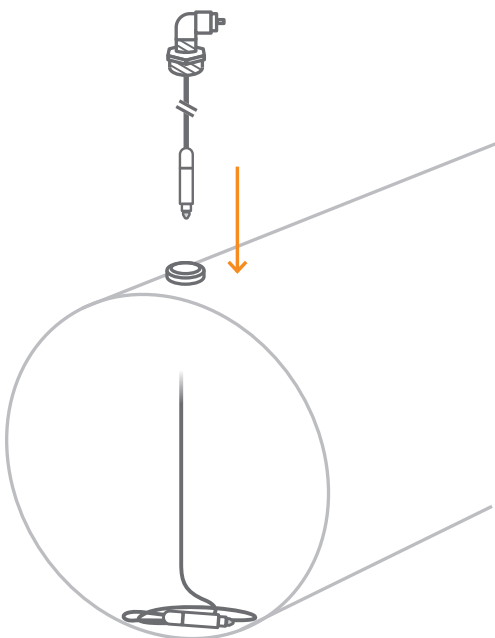

5. Screw the reducer into the port hole and tighten with a wrench. On the final torque, make sure the female M12 connector at the elbow's exit is oriented toward the communicator.

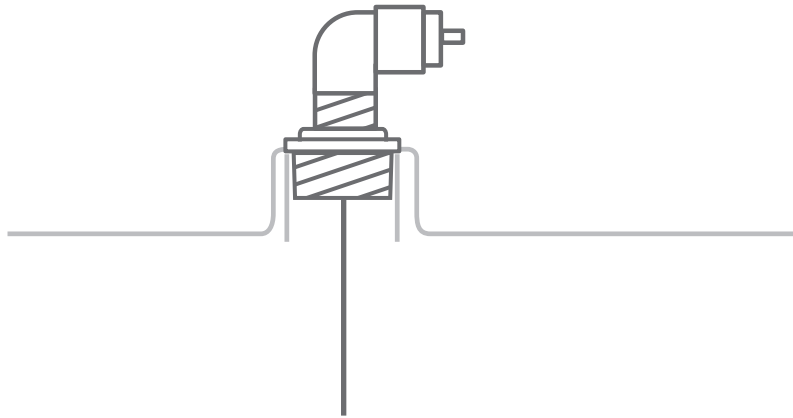

The sensor is now installed in the tank.

**Caution**

Do not overtighten the threads or you may damage the pipe fittings.

6. Connect the M12 male-to-male extension cable (30 inch / 0.77 m) to the sensor assembly and communicator by doing the following:
  - a. Plug one end of the extension cable into the female M12 connector at the elbow exit.
  - b. Line up the M12 connector pins with the corresponding holes in the bulk head of the communicator and plug the other end into the female M12 port on the communicator. Refer to the alignment guide (plastic notch) for easy fastening.

You can now mount the communicator.

For more information, see Mounting the communicator on [page 26](#).

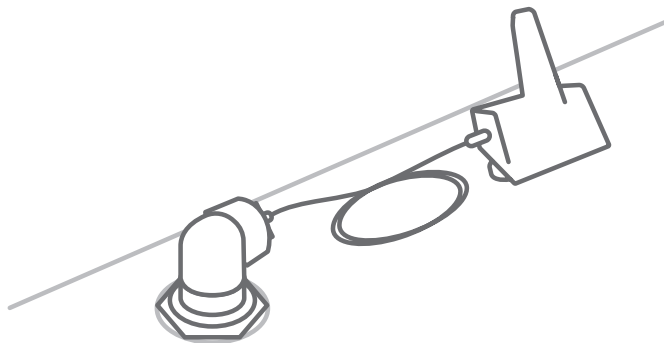

## 4.4 Mounting the communicator

The communicator can be mounted directly on the top of a metal tank using the magnetic feet attached to the communicator base. No other fixings are required.

If you are mounting the communicator on the side of a metal tank, you need to use an additional magnetic bracket (SKU ACCMMK-NV4).

If you are mounting the communicator on a plastic tank or other types of nonmagnetic tanks, use tie wraps to attach the communicator to the tank, or the tank cage.



### Notice

Before you mount the communicator, make sure you read the instructions for maximizing the performance of the communicator.

➤ For more information, see [Maximizing communicator performance on page 18](#).



### Information

Otodata recommends you position the communicator away from the t-vent.

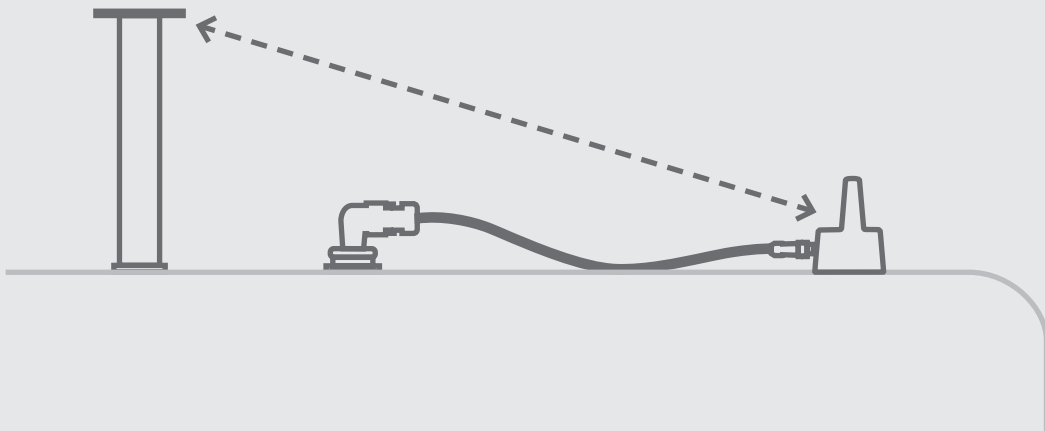

### To mount the communicator, follow these steps:

1. Select the optimal location for the communicator.
2. Note down the relevant information from identification label on the base of the communicator.

You will need to enter this information when you are updating client information in Otodata's Nee-Vo Portal.

3. Do one of the following:

- a. If you are mounting the communicator on the top of a metal tank, use the mounting magnets to secure the communicator to the tank.
  - b. If you are mounting the communicator on the side of a metal tank, follow the instructions for the SKU ACCMMK-NV4 magnetic bracket.
- For more information, see [Installing the mounting bracket for metal tanks on page 27](#).
- c. If you are mounting the communicator on a plastic or non-magnetic tank, thread the tie wraps through the hooks on the back of the communicator and fasten the tie wraps to the tank.

#### 4.4.1 Installing the mounting bracket for metal tanks

Install the ACCMMK-NV4 bracket if you want to mount the communicator on the side of a metal tank.

Before you start, check you have the following components:

- 1 x vertical bar
- 1 x horizontal bar
- 2 x magnets
- 2 x rubber spacers
- 2 x screws

**Figure 10 • Mounting bracket components**

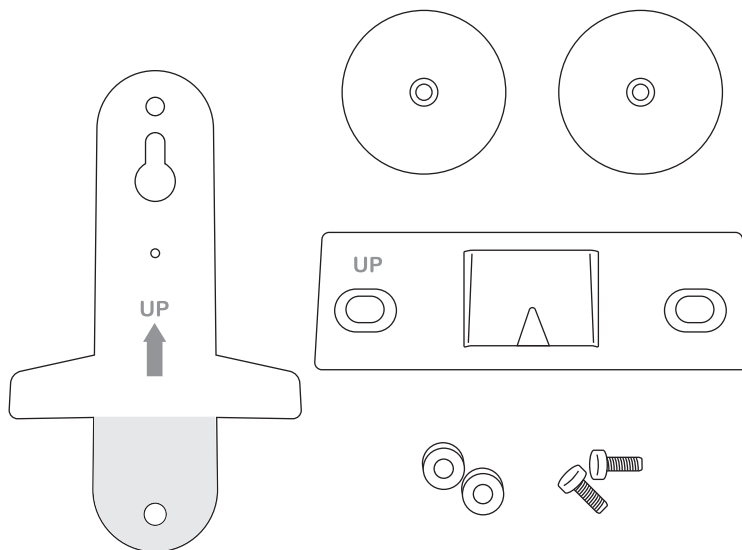

**To install the bracket, follow these steps:**

1. Gently insert the vertical bar through the center slot of the horizontal. Make sure UP is visible on both bars.

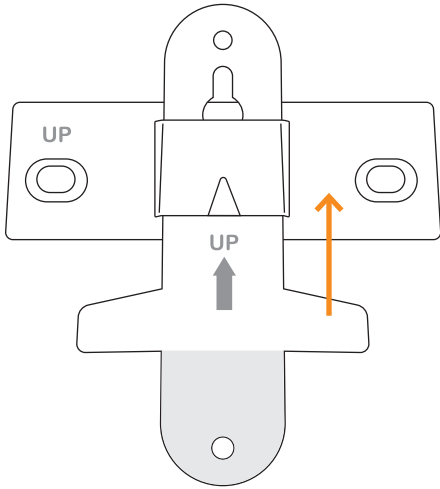

2. Turn the bracket over.
3. Attach the magnets to the vertical bar using the rubber spacers and screws.

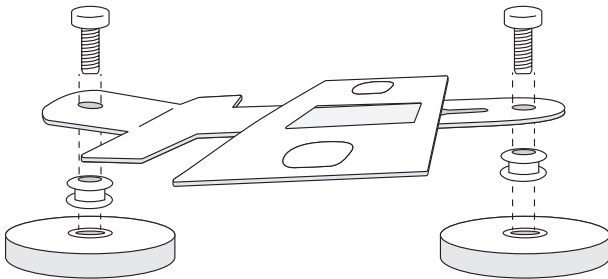

4. Slide the horizontal bar of the bracket all of the way into the right-side handle on the back of monitor.

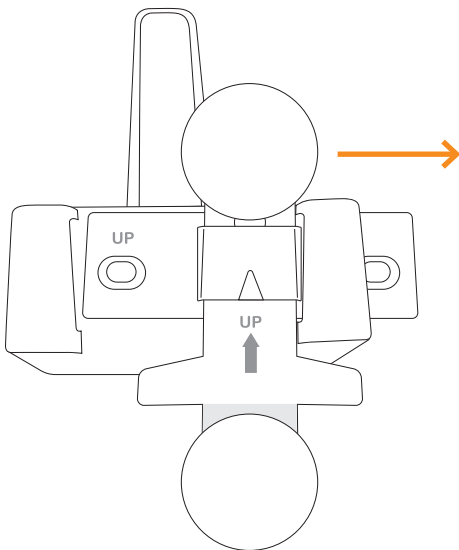

5. Push the horizontal bar of the bracket through the left-side handle. Make sure the horizontal bracket is correctly centered between both handles.

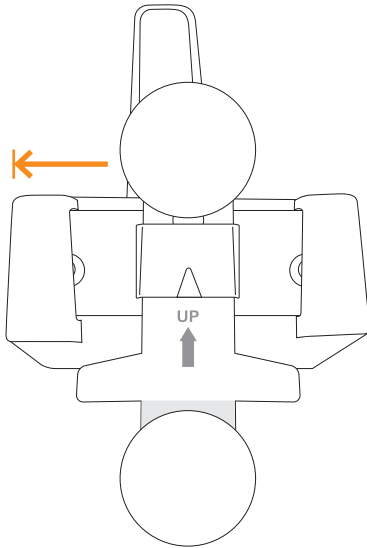

6. Push the vertical bar of the bracket upward until it locks into place.

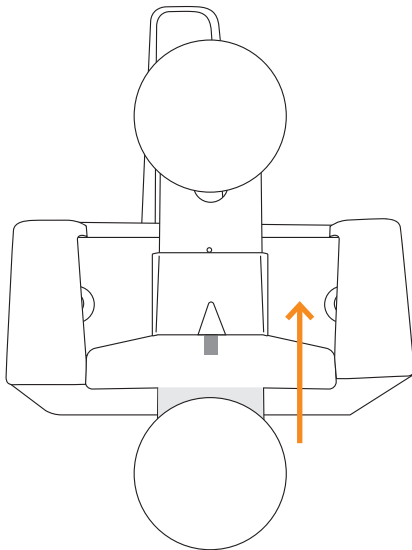

The bracket is installed.

## 5 Maintenance

The monitor requires minimum maintenance. During fill operations, Otodata recommends the following are checked:

- There are no signs of physical damage to any part of the monitor
- The M12 male-to-male extension cable is securely connected at both ends and is undamaged.
- The communicator is in an upright position

### 5.1 Cleaning the sensor

Cleaning the sensor makes sure the HP monitor readings are accurate.

**To clean the Gauge Reference sensor, follow these steps:**

1. Disconnect the M12 male-to-male extension cable from the female M12 connector at the elbow exit.

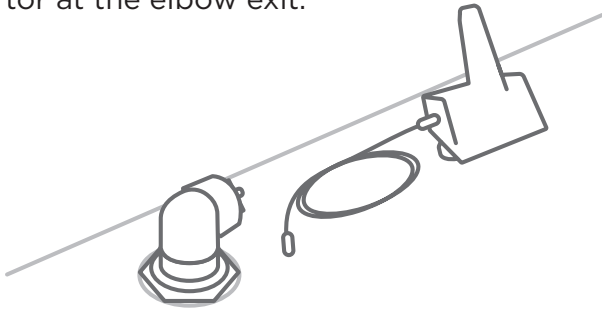

2. Unscrew the reducer connecting the sensor to the port hole of the tank.
3. Carefully pull the sensor up through the port hole and out of the tank.

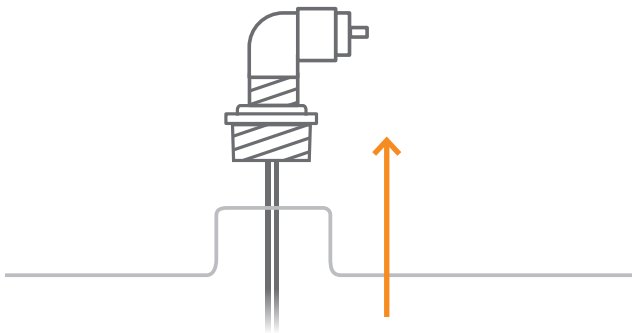

4. To clean the sensor, on a clean flat surface, use a cleaner to rinse off the outside of the sensor.



**Notice**

Make sure the cleaner is suitable for the sensor and the contents of the tank. The cleaner must not adversely affect the sensor or its components.

5. Remove the depth cone ① from the sensor shaft ② by turning it counterclockwise.

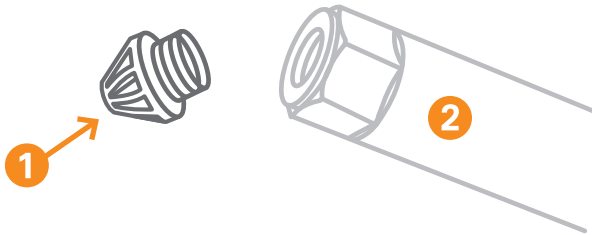

6. Using the cleaner, thoroughly rinse the inside of the depth cone to remove any dirt, grease, or debris. Check the small slots in the depth cone are clean.

**Caution**

Do not overtighten the threads or you may damage the pipe fittings.

7. Towel or air dry the depth cone and the sensor shaft.
8. Reinstall the depth cone by screwing it clockwise into the sensor shaft.
9. Reinstall the sensor by slowly lowering it through the port hole until you feel it touch the bottom of the tank.
10. If required, reapply an approved sealant to the thread of the reducer.
11. Screw the reducer into the port hole and tighten with a wrench. On the final torque, make sure the female M12 connector at the elbow exit is oriented toward the communicator.

**Caution**

Do not overtighten the threads or you may damage the pipe fittings.

12. Reconnect the M12 male-to-male extension cable to the female M12 connector at the elbow exit and to the female M12 port on the communicator.

## 6 Troubleshooting

The following table provides troubleshooting information for the monitor.

**Table 6 • Troubleshooting table**

Problem	Solution
The monitor is not reading the tank level correctly	<ul style="list-style-type: none"> <li>• Check the tank size is compatible with the sensor.               <ul style="list-style-type: none"> <li>▶ For more information, see <a href="#">Checking tank compatibility on page 16</a>.</li> </ul> </li> <li>• Check both ends of the M12 male-to-male extension cable are fully seated — one end in the female M12 connector at the elbow exit, and the other end in the female M12 port on the communicator.</li> <li>• Check the Gauge Reference sensor is correctly installed in the tank.               <ul style="list-style-type: none"> <li>▶ For more information, see <a href="#">Installing the Gauge Reference sensor on page 23</a>.</li> </ul> </li> </ul>
The communicator is not sending monitor readings	<ol style="list-style-type: none"> <li>1. Check the communicator is in a vertical position with the antenna pointing skywards.</li> <li>2. Check the communicator is positioned away from any walls.</li> <li>3. Check that there is adequate cellular coverage in the area where the communicator is installed.</li> </ol>

## 7 Specifications

The specifications provide the limits of the HP monitor. Make sure you are aware of these specifications.

### 7.1 Device specifications

Table 7 • Device specifications

Specification	Value
Dimensions (H x W x D)	6.3" (16 cm) x 5.1" (13 cm) x 4.3" (11 cm)
Applications	Measures the level of gasoline, chemicals, or other in-tank substances  Contact Otodata Customer Support for a list of substances that are compatible with the Hydrostatic Pressure Tank Level Monitor TM5240HP sensor
Characteristics	MEAS TE pressure cell, Volume measurement accuracy $\pm 5\%$ (under optimal setup and installation conditions)  Survives harsh environments  Suitable for tank heights up to 52 ft (16 m)  Hytrel jacketed cable lengths available in 6 ft (1.8 m), 9 ft (2.7 m), 15 ft (4.6 m), 30 ft (9.1 m), 36 ft (11 m), and 55 ft (16.8 m)
Input	Hydrostatic pressure transducer with gauge reference — atmospheric pressure is referenced internally via capillary tube terminating in the tank headspace behind a PTFE membrane.

Reporting	<p>Typically records and reports the in-tank level when it detects a level change exceeding +20% or dropping by more than 5% of the sensor's full measurement range</p> <p>Tank level data is sent to the Nee-Vo Portal every 8 hours. Each transmission includes one reading per hour, covering the previous 8 hours</p> <p>Low battery</p> <p>High draw of in-tank substance</p> <p>Excessive draw of in-tank substance</p> <p>Fill detection</p> <p>Temperature of in-tank substance</p>
Data interface outputs	<p>API</p> <p>Email to supplier and/or consumer</p> <p>Raw data</p> <p>Online dashboard</p> <p>Client mobile app</p>
Automated testing outputs	<p>Network status</p> <p>Sensor cable status</p> <p>Battery status</p>
Radio technologies	<p>CAT-M1</p> <p>NB-IoT</p> <p>Dual SIM</p> <p>Bluetooth</p>
Option	<p>GPS (mobile tank)</p>

## 7.2 Environmental specifications

Table 8 • Environmental specifications

Specification	Value
Operating temperature	-40 °F (-40 °C) to 140 °F (60 °C)
Storage temperature	-40 °F (-40 °C) to 140 °F (60 °C)
Relative humidity range	0% to 100%
Enclosure rating	IP68
Sensor rating	IP68

## 7.3 Certification specifications







Table 9 • Certification specifications

Specification	Value
Hazardous location classification	Monitor is third-party QPS Evaluation Services Inc. certified for use in hazardous locations Class I, Div 1, Groups CD, T3 Ex ia IIB T3 Ga Class I, Zone 0, AEx ia IIB T3 Ga
IECEX Classification	Ex ia IIB T3 Ga
ATEX and UKEX Classification	II 1 G Ex ia IIB T3 Ga
FCC Notice	FCC ID: 2ADQFMZ03AD, IC ID : 12649A-MZ03AD
Associated Apparatus Entity Parameters	Uo [V] = 3.9V, Io [mA] = 335mA, Po [mW] = 119mW, Co [μF] = 425uF, Lo [μH] = 10.17uH

## 8 Regulatory

The following table provides information about the regulations to which the monitor conforms.

**Table 10 • Standards table with symbols**

Standard	Symbol
The Conformité Européene (CE) mark	
UK Conformity Assessed	
National Telecommunications Agency (ANATEL)	
Waste Electrical and Electronic Equipment (WEEE)	
National Institute of Metrology, Quality and Technology (INMETRO)	
QPS Safety Certification Mark	



### Information

Mounting fittings, for example, the polypropylene elbow, are not part of the certification for the HP monitor.

## 8.1 Federal Communications Commission (FCC)

This device complies with part 15 of the FCC Rules. Changes or modifications not expressly approved by the party responsible for compliance could void the user's authority to operate the equipment.

Operation is subject to the following two conditions: (1) This device may not cause harmful interference, and (2) this device must accept any interference received, including interference that may cause undesired operation. This device is compliant with Industry Canada's RSS standards for license-exempt radio apparatuses.

Authorized use depends on the following two conditions: (1) the device must not create radio interference, and (2) the device user must accept all radio interference, even if this interference could potentially impair its functioning.

This equipment has been tested and found to comply with the limits for a Class B digital device, pursuant to part 15 of the FCC Rules. These limits are designed to provide reasonable protection against harmful interference in a residential installation. This equipment generates, uses and can radiate radio frequency energy and, if not installed and used in accordance with the instructions, may cause harmful interference to radio communications. However, there is no guarantee that interference will not occur in a particular installation.

If this equipment does cause harmful interference to radio or television reception, which can be determined by turning the equipment off and on, the user is encouraged to try to correct the interference by one or more of the following measures:

- Reorient or relocate the receiving antenna.
- Increase the separation between the equipment and receiver.
- Connect the equipment into an outlet on a circuit different from that to which the receiver is connected.
- Consult the dealer or an experienced radio/TV technician for help.

To comply with FCC RF exposure compliance recommendations, a separation distance of at least 20 cm must be maintained between the antenna of this device and all persons.